

USN

--	--	--	--	--	--	--	--	--	--

18ELN14/24

First/Second Semester B.E. Degree Examination, July/August 2022 Basic Electronics

Time: 3 hrs.

Max. Marks: 100

Note: Answer any FIVE full questions, choosing ONE full question from each module.

Module-1

- 1 a. Explain the diode characteristics under forward and reverse biased condition with neat diagram. (06 Marks)
- b. What is a voltage regulator? Explain with a neat diagram the working of a zener voltage regulator. (06 Marks)
- c. With a neat diagram and waveforms, explain the working of a bridge rectifier. Derive the efficiency of this rectifier. (08 Marks)

OR

- 2 a. Explain the working of a centre tap full wave rectifier, with a neat diagram and waveform. Derive the ripple factor for it. (08 Marks)
- b. What is an LED? Explain the working of an LED, with a neat diagram. (06 Marks)
- c. In the zener voltage regulator, $V_Z = 10V$, $R_S = 1 K\Omega$, $R_L = 2 K\Omega$. If the input voltage V_i is varied from 22 V to 40 V, find the maximum and minimum value of zener current. [Refer Fig.Q2(c)]

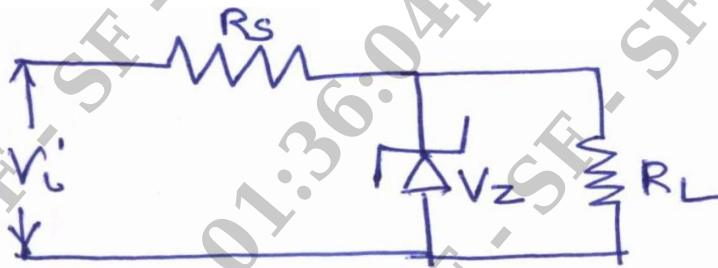

Fig.Q2(c)

(06 Marks)

Module-2

- 3 a. With a neat graph for the drain characteristics of an N channel JFET, explain the following:

(i) Cut-off voltage	(ii) ohmic region
(iii) Pinch off voltage	(iv) Break-down

(08 Marks)
- b. What is commutation? Explain one method of commutation of an SCR with neat diagram. (06 Marks)
- c. For an n channel JFET, $I_{DSS} = 9 \text{ mA}$ and $V_{GS(off)} = -8 \text{ V}$ (maxm), using these values determine the drain current for $V_{GS} = 0V; -1 \text{ V}, \text{ and } -4 \text{ V}$. (06 Marks)

OR

- 4 a. With neat circuit diagrams, explain the construction and operation of an enhancement type MOSFET. (08 Marks)
- b. How is CMOS used as an inverter? Explain with neat diagram. (06 Marks)
- c. Explain the switching action of an SCR using two transistor model. (06 Marks)

Important Note : 1. On completing your answers, compulsorily draw diagonal cross lines on the remaining blank pages.
2. Any revealing of identification, appeal to evaluator and /or equations written eg. 42+8 = 50, will be treated as malpractice.

Module-3

- 5 a. With neat diagrams and explanation analyze a differential input op-amp amplifier. (06 Marks)
- b. With respect to an op-amp, explain the following and give their ideal values:
- (i) CMRR
 - (ii) PSRR
 - (iii) Input offset voltage
 - (iv) Input offset current
- (08 Marks)
- c. With relevant diagram and derivation show how an op-amp can be used as inverting summing amplifier (Adder). (06 Marks)

OR

- 6 a. Explain how an op-amp can be used as a difference amplifier with neat diagram. (08 Marks)
- b. For the circuit of the inverting amplifier shown in Fig.Q6(b), calculate the following:
- (i) Closed loop gain A_f
 - (ii) Output voltage V_o
 - (iii) Input current I_i
 - (iv) Feedback current I_f

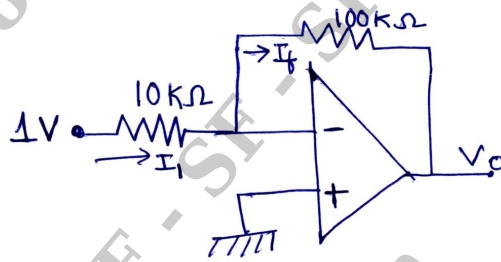

Fig.Q6(b)

(06 Marks)

- c. For the circuit Fig.Q6(c), calculate the output voltage of V_{o1} and V_{o2} .

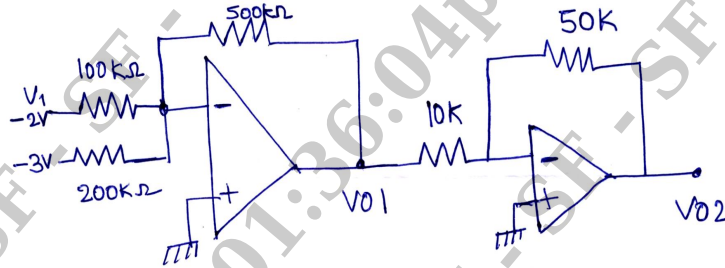

Fig.Q6(c)

(06 Marks)

Module-4

- 7 a. How does a transistor voltage amplifier work? Explain and also derive the equation for voltage gain. (08 Marks)
- b. With relevant diagrams and equations, explain the concept of positive and negative feedback amplifier concept. (06 Marks)
- c. Determine the voltage gain and the ac output voltage if $r'e = 50 \Omega$ for the circuit shown in Fig.Q7(c). What value of R_C will get a voltage gain of 50?

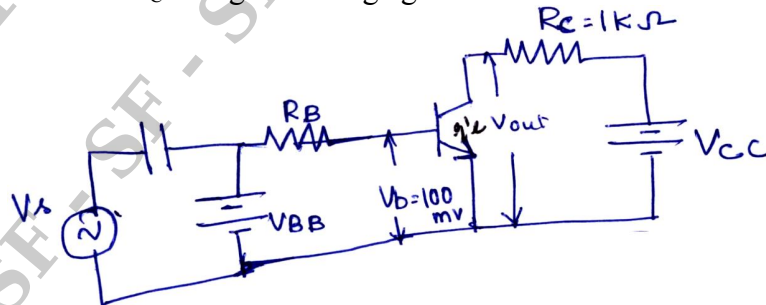

Fig.Q7(c)

(06 Marks)



OR

- 8 a. How does a transistor function like a switch? Explain with relevant diagrams. (06 Marks)
b. With a neat circuit diagram, explain RC phase shift oscillator. Write the equation for the frequency of oscillation. (08 Marks)
c. With relevant diagram, explain the internal block diagram of IC 555 Timer. (06 Marks)

Module-5

- 9 a. Realize a full adder using two half adders. Derive the expression for sum and carry. (08 Marks)
b. Convert the following as indicated:
(i) $(FACE)_{16} = ()_2$
(ii) $(1001101)_2 = ()_8$
(iii) $(126)_8 = ()_{10}$
(iv) $(1689)_{10} = ()_{16}$ (08 Marks)
c. Subtract 11010 from 10111 using 2's complement method. (04 Marks)

OR

- 10 a. With a neat circuit diagram, explain the block diagram of a GSM system. (08 Marks)
b. Explain the working of a RS latch with neat diagram and function table. (06 Marks)
c. Prove the following identities using truth table:
(i) $\overline{A \cdot B} = \overline{A} + \overline{B}$
(ii) $A \cdot (A + B) = A$ (06 Marks)
